

Economizer Retrofit Solutions

- ZIP Code patented technology will automatically recognize your climate zone and will set the high limit change over temperature providing automatic compliance.
- Plug and Play self-configuring; if it's not plugged into the economizer, you won't have to worry about setting it up.
- Integrated onboard test sequence that ensures effortless compliance with California Title 24 and verification of proper operation.
- Fault Detection and Diagnostics (FDD) troubleshoot faults, initiates alarms, and reconfigures for best operation.
- Easy-to-read automotive grade LCD display delivers clear live status information, easy setup, changes, and operating history even in the brightest of days, and coldest of days.
- First and only economizer control that integrates onboard help for setup or troubleshooting.



Applications

The ZIP Economizer™ saves energy in buildings by using cool outside air as a means of cooling the indoor space. The ZIP can reduce HVAC energy costs in cold and temperate climates while also improving indoor air quality. As energy codes change towards continual efficiency, the ZIP Economizer satisfies all the requirements. ZIP Economizer, with its 'plug and play' modular design and patented ZIP Code setup, allows an easy way to ensure maximum energy savings and compliance with local energy codes.



ECON-ZIP BASE

AND



ECON-ZIP-10K
(Supply Air Sensor)

Economizer Base



TFB24-SR
up to 7.5 Tons



LF24-SR
7.5-12 Tons



NFB24-SR
12-15 Tons



AFB24-SR
15-30 Tons

Select Actuator

DRY BULB



ECON-ZIP-10K

ENTHALPY



ECON-ZIP-TH

Note: Differential control requires one additional sensor for return air.

OR

Select High Limit
Changeover Sensors

Optional Add-On
Modules



- Demand Control Ventilation (DCV)* - ECON-ZIP-EM + CO2 sensor of your choice (0-2000PPM, 0-10VDC).
- Preoccupancy Purge* - ECON-ZIP-EM Requires thermostat with purge setting and contacts.
- Remote Damper Override - ECON-ZIP-EM + SGA24
- Exhaust Fan - ECON-ZIP-EM

- Remote Alarm Notification* - ECON-ZIP-COM

* May be required by local codes



Honeywell W7210



Belimo ZIP Economizer

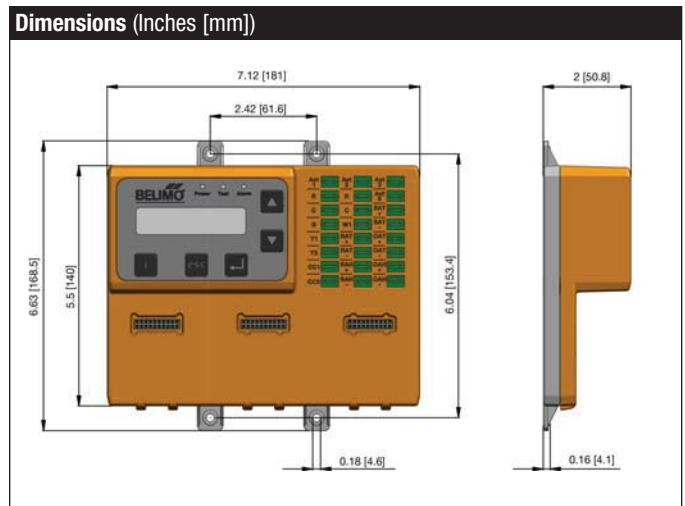
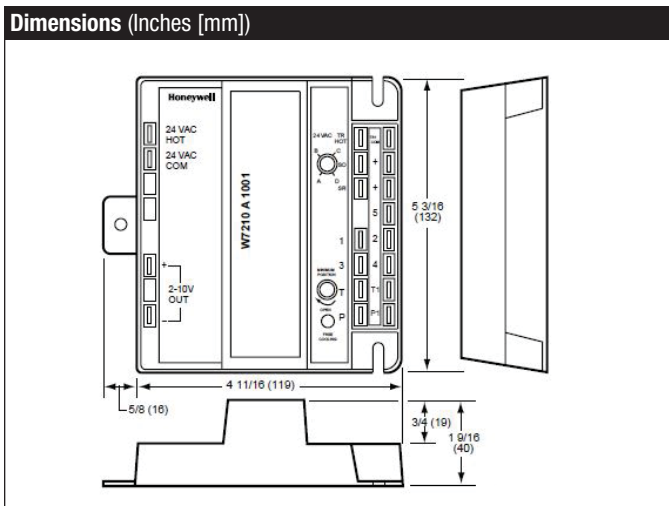

Tech.Doc - 07/14 - Subject to change. © Belimo Aircontrols (USA), Inc.

W7210 WIRE TERMINATION	ZIP ECONOMIZER WIRE TERMINATION
1	Y1
2	CC1
3	Y2
4	CC2
5	NA
TR	R
TR1	C
ST6008 OCC Timer	G
P-P1	AUX2 Located on ECON-ZIP-EM
T-T1	Supply Air – New Sensor
So-So+	Outside Air- New Sensor
Sr-Sr+	New Sensors
+	ACT3
-	ACT1
24 VAC HOT	ACT2
	ACT5



Honeywell W7212



Belimo ZIP Economizer

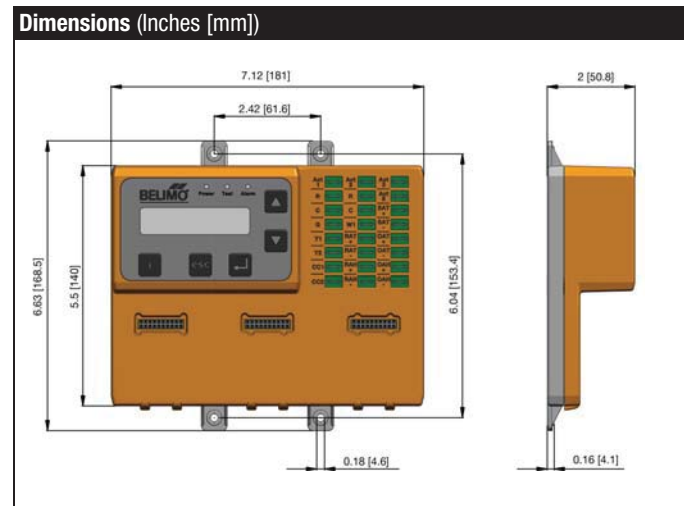
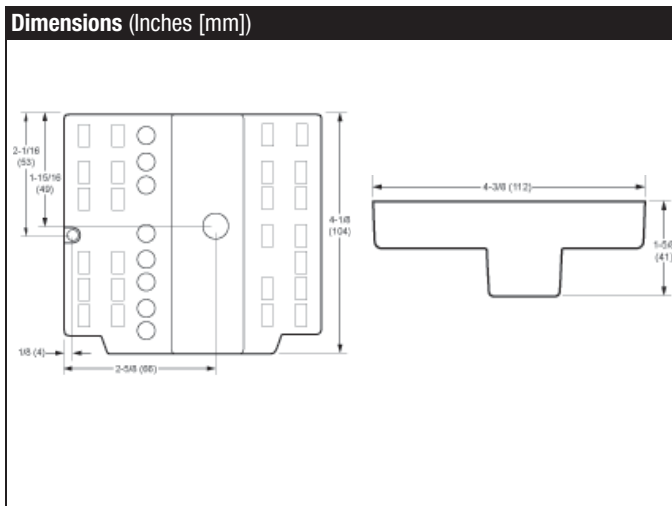

W7212 WIRE TERMINATION	ZIP ECONOMIZER WIRE TERMINATION
1	Y1
2	CC1
3	Y2
4	CC2
5	NA
TR	R
TR1	C
N	G
P-P1	AUX2 Located on ECON-ZIP-EM
T-T1	Supply Air – New Sensor
So-So+	Outside Air- New Sensor
AQ-AQ1	New Sensors
EF-EF1	C02 +/- EF*

*EF, EFH1 provide 24 VAC out. Interposing relay or contactor may be needed for exhaust fan control. Verify with RTU wiring.

Tech.Doc - 07/14 - Subject to change. © Belimo Aircontrols (USA), Inc.



Honeywell W7459



Belimo ZIP Economizer

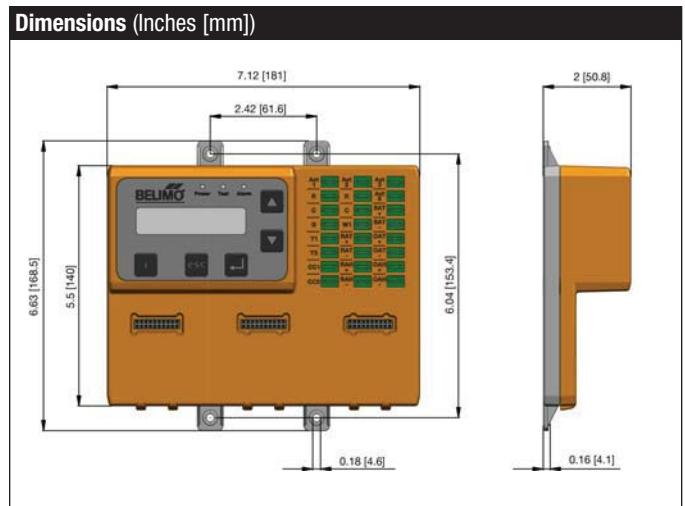
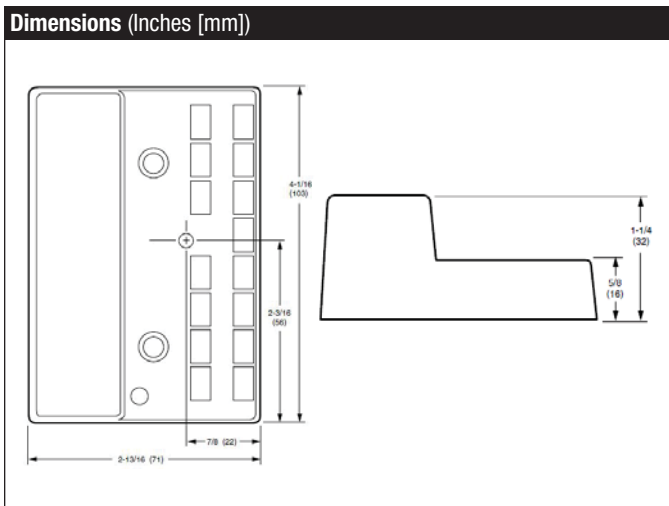

Tech.Doc - 07/14 - Subject to change. © Belimo Aircontrols (USA), Inc.

W7459 WIRE TERMINATION	ZIP ECONOMIZER WIRE TERMINATION
1	Y1
2	CC1
3	Y2
4	CC2
5	NA
TR	R
TR1	C
N	G
P-P1	AUX2 Located on ECON-ZIP-EM
T-T1	Supply Air - New Sensor
So-So+	Outside Air - New Sensor
Sr-Sr+	New Sensors

BELIMO RETROFIT KITS

Part Number	Description	Components (# included in kit)
ECON-ZIP-ACT	Actuator Shaft Adapter allows easy retrofit from Honeywell® black box motors (M7XXX) to Belimo spring return actuator.	Shaft, M4x8 Screws (4), Locking Nuts (4)
ECON-ZIP-LF1	Bracket with hole patterns to mount the LF Series actuator, horizontal or vertical position to meet space requirements.	ECON-ZIP-ACT, ZG-112, Screws
ECON-ZIP-TF1	Bracket with hole patterns to mount the TF Series actuator, horizontal or vertical position to meet space requirements.	ECON-ZIP-ACT, ZG-113, Spacers and Screws

BELIMO ZIP PACK

Part Number	Description	Components (# included in kit)
ECON-ZIP-SDTF	Single Dry Bulb with DCV Capability and TF Spring Return Actuator (22 in-lbs)	ECON-ZIP-Base, ECON-ZIP-EM, ECON-ZIP-10K (2), TFB24-SR, ECON-ZIP-TF1
ECON-ZIP-DDTF	Differential Dry Bulb with DCV Capability and TF Spring Return Actuator (22 in-lbs)	ECON-ZIP-BASE, ECON-ZIP-EM, ECON-ZIP-10K (3), TFB24-SR, ECON-ZIP-TF1
ECON-ZIP-SETF	Single Enthalpy with DCV Capability and TF Spring Return Actuator (22 in-lbs)	ECON-ZIP-BASE, ECON-ZIP-EM, ECON-ZIP-10K, ECON-ZIP-TH, TFB24-SR, ECON-ZIP-TF1
ECON-ZIP-SDLF	Single Dry Bulb with DCV Capability and LF Spring Return Actuator (35 in-lbs)	ECON-ZIP-BASE, ECON-ZIP-EM, ECON-ZIP-10K (2), LF24-SR US, ECON-ZIP-LF1
ECON-ZIP-DDLF	Differential Dry Bulb with DCV Capability and LF Spring Return Actuator (35 in-lbs)	ECON-ZIP-BASE, ECON-ZIP-EM, ECON-ZIP-10K (3), LF24-SR US, ECON-ZIP-LF1
ECON-ZIP-SELF	Single Enthalpy with DCV Capability and LF Spring Return Actuator (35 in-lbs)	ECON-ZIP-BASE, ECON-ZIP-EM, ECON-ZIP-TH, ECON-ZIP-10K, LF24-SR US, ECON-ZIP-LF1

HONEYWELL Y PACK		BELIMO ZIP PACK	
Part Number	Description	Part Number	Description
Y7220A7215	Dry Bulb with black motor	ECON-ZIP-SDTF	Single Dry Bulb with DCV Capability, 22 in-lbs
YL7220A7503	Dry Bulb with non-communicating DCA	ECON-ZIP-SDTF	Single Dry Bulb with DCV Capability, 22 in-lbs
YL7220AJ3103	Dry Bulb with communicating 27 in-lbs DCA	ECON-ZIP-SDTF*	Single Dry Bulb with DCV Capability, 22 in-lbs
YL7220AJ3105	Dry Bulb with communicating 44 in-lbs DCA	ECON-ZIP-SDLF*	Single Dry Bulb with DCV Capability, 35 in-lbs
Y7220S7215	Enthalpy with black motor	ECON-ZIP-SETF	Single Enthalpy with DCV Capability, 22 in-lbs
YL7220S7503	Enthalpy with non-communicating DCA	ECON-ZIP-SETF	Single Enthalpy with DCV Capability, 22 in-lbs
YL7220SJ3103	Enthalpy with communicating 27 in-lbs DCA	ECON-ZIP-SETF*	Single Enthalpy with DCV Capability, 22 in-lbs
YL7220SJ3105	Enthalpy with communicating 44 in-lbs DCA	ECON-ZIP-SELF*	Single Enthalpy with DCV Capability, 35 in-lbs

*May be a lower torque cross, but acceptable for damper.

Single Dry Bulb

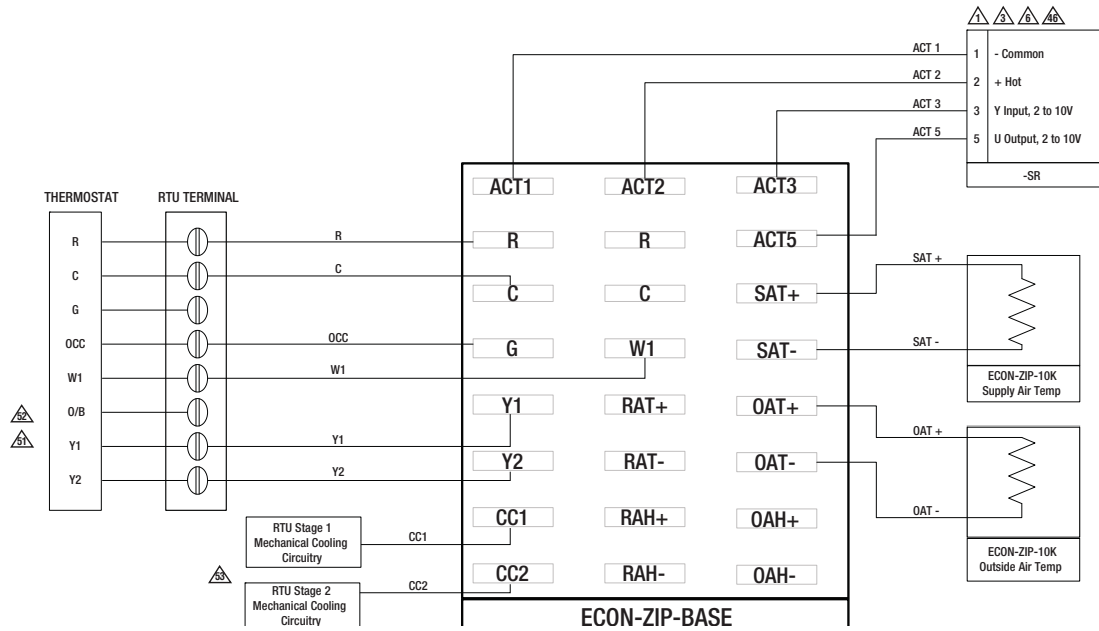

Differential Dry Bulb

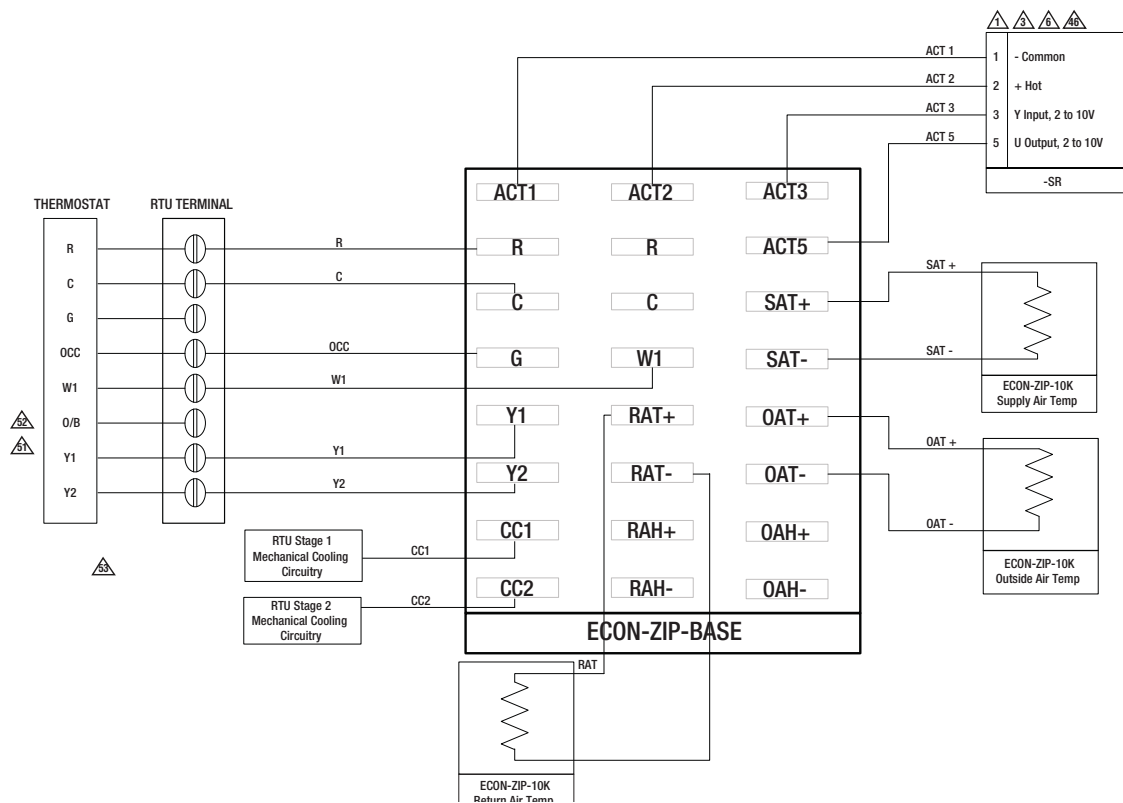

Tech.Doc - 07/14 - Subject to change. © Belimo Aircontrols (USA), Inc.

Single Enthalpy

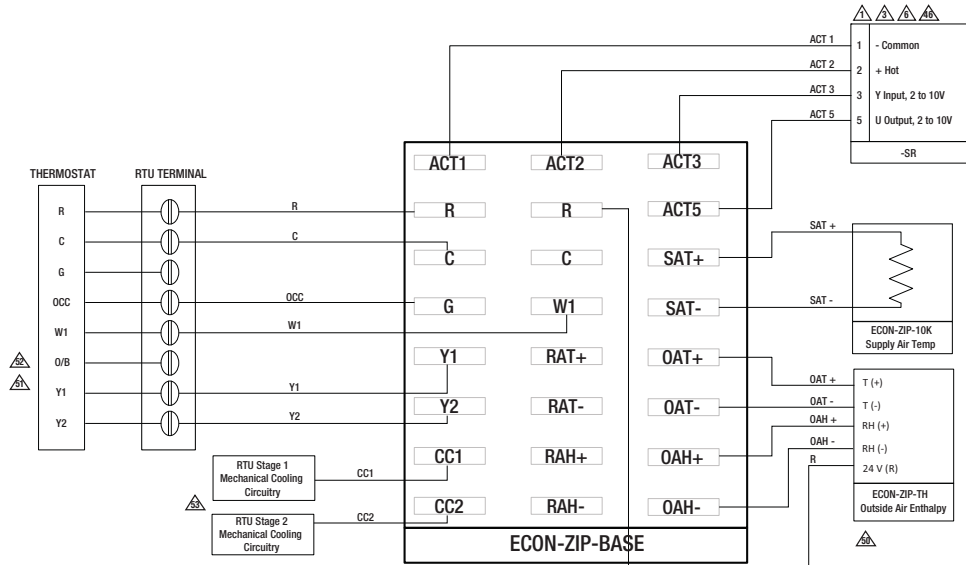

Differential Enthalpy

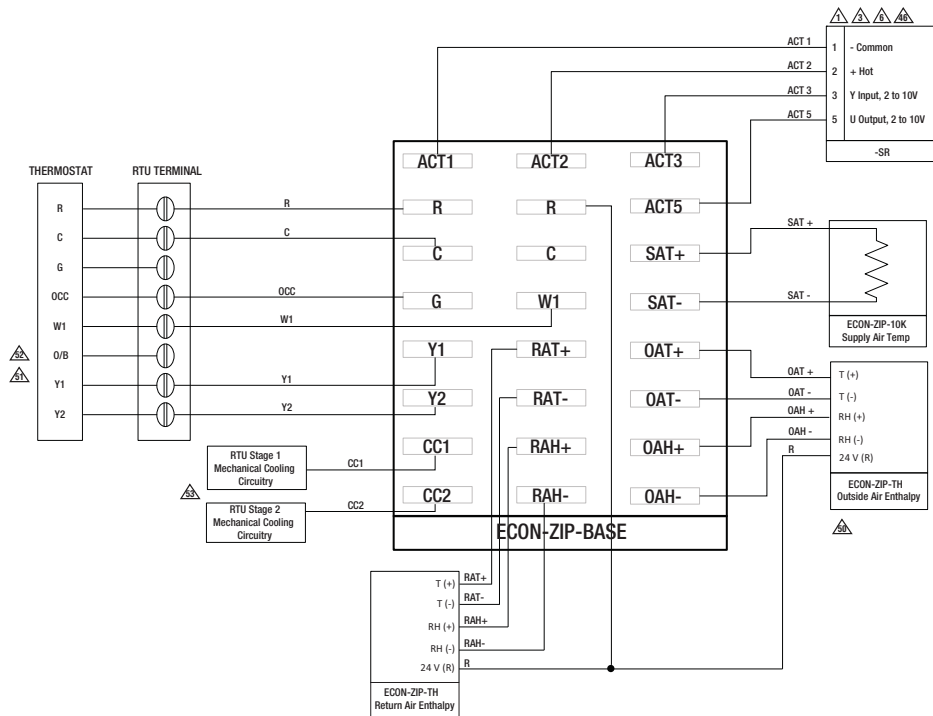

ECON-ZIP-EM

